

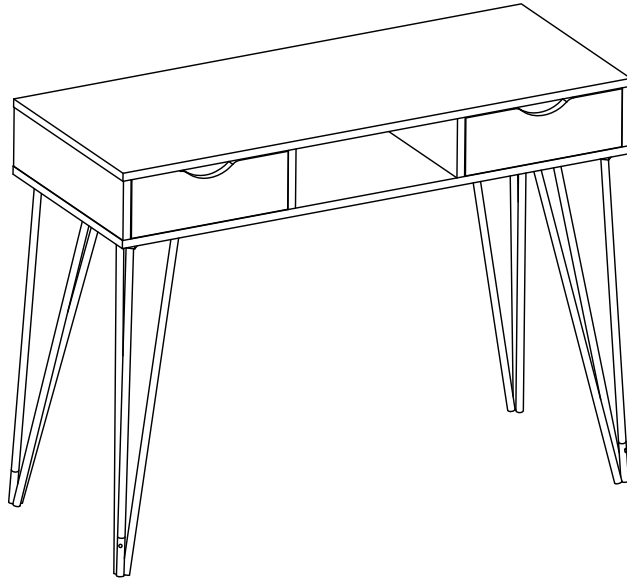







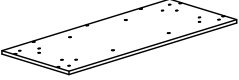
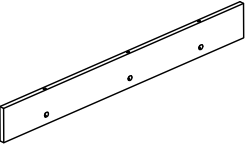
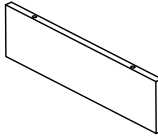
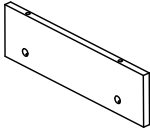
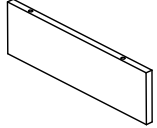
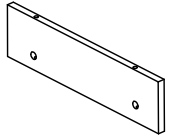
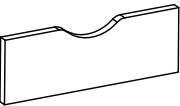
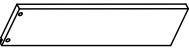
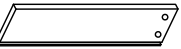
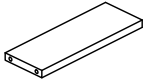
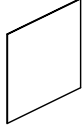
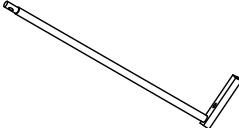
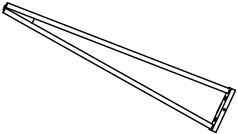
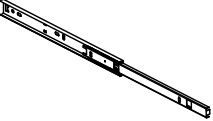
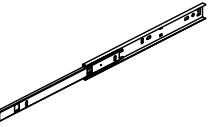

ASSEMBLY INSTRUCTION

DO NOT TIGHTEN SCREWS UNTIL COMPLETELY ASSEMBLED

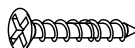
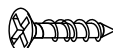

								
A×1PC	B×1PC	C×1PC	D×1PC	E×1PC	F×1PC	G×1PC	H×2PCS	
								
I×2PCS	J×2PCS	K×2PCS	L×2PCS	M×4PCS	N×4PCS	O×2PCS	P×2PCS	
								
Q×19PCS	R×19PCS	S×11PCS	T×8PCS	U×16PCS	V×4PCS	W×12PCS	X×4PCS	Y×1PC

Step 1

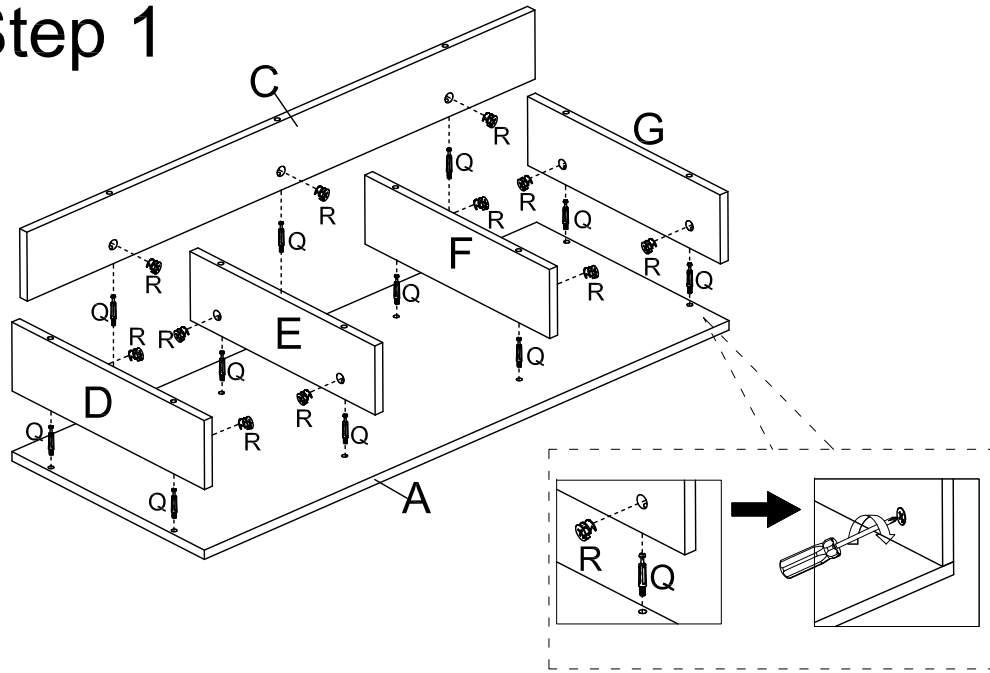

Step 2

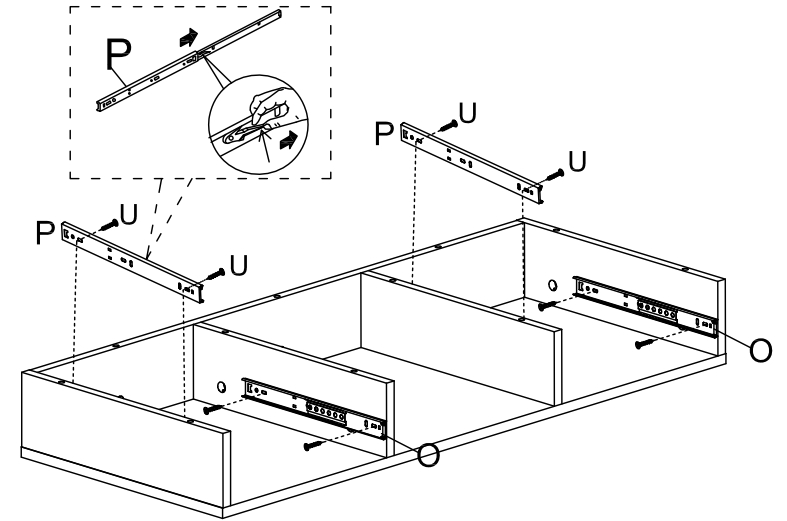

Step 3

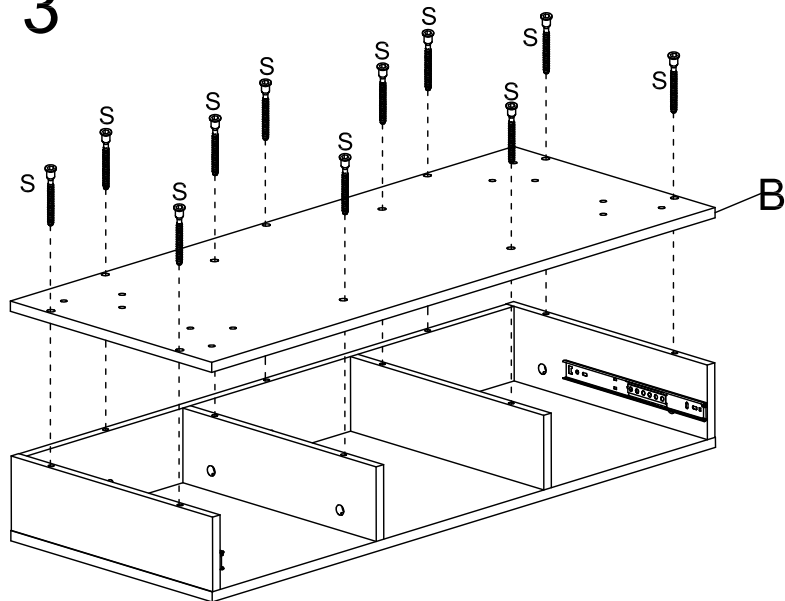

Step 4

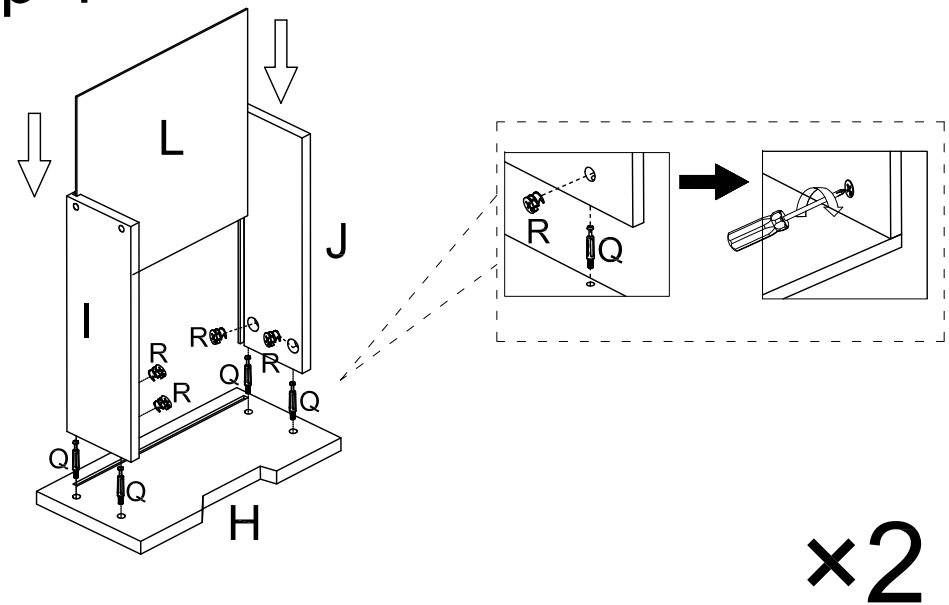

Step 5

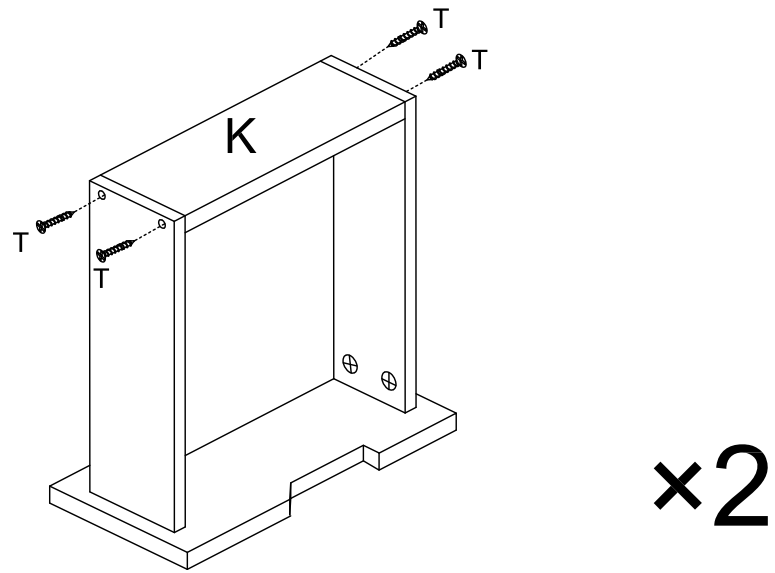

Step 6

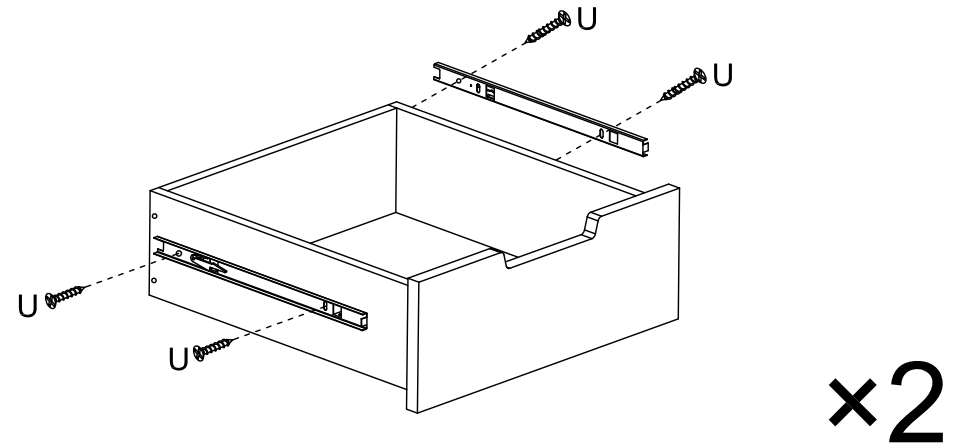

Step 7

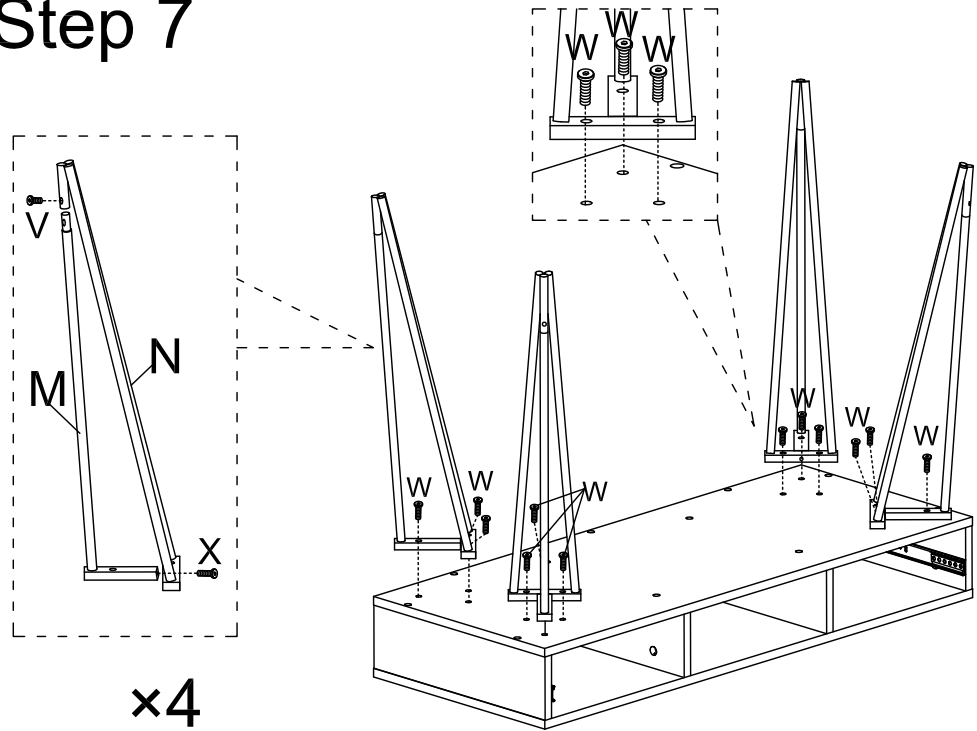

Step 8

