











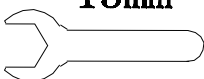

①	 M6x20	8 TEM	⑧	 5mm	1 TEM
②	 M6x40	8 TEM	⑨	 10mm	1 TEM
③	 M8x50	8 TEM	⑩	 13mm	1 TEM
④	 M8	8 TEM	⑪	 12 TEM	12 TEM
⑤	 M6	9 TEM	⑫	 24 TEM	24 TEM
⑥	 M8	4 TEM	⑬	 13 TEM	13 TEM
⑦	 4mm	1 TEM	⑭	 M6x55	1 TEM



ΒΗΜΑ9

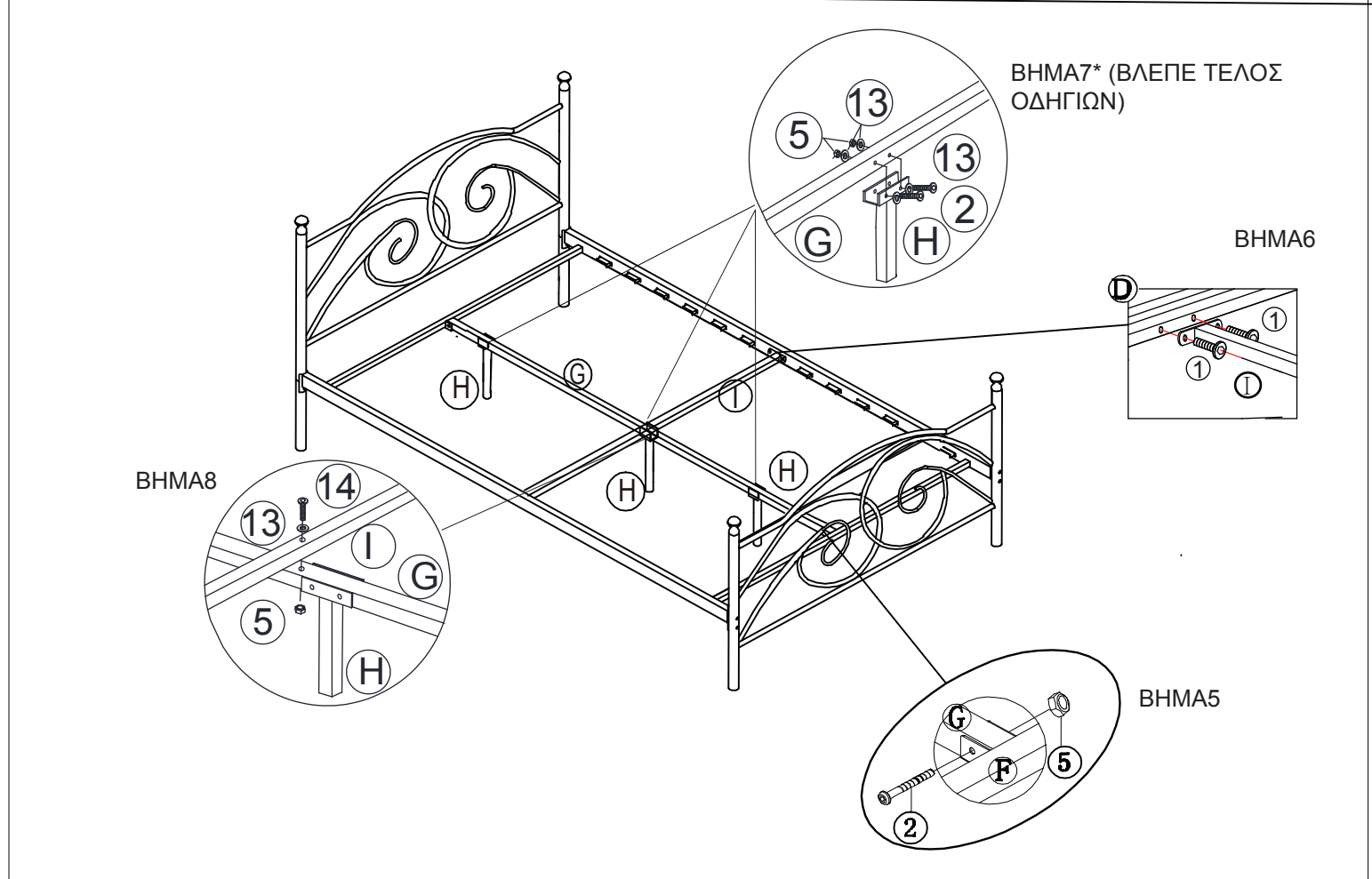
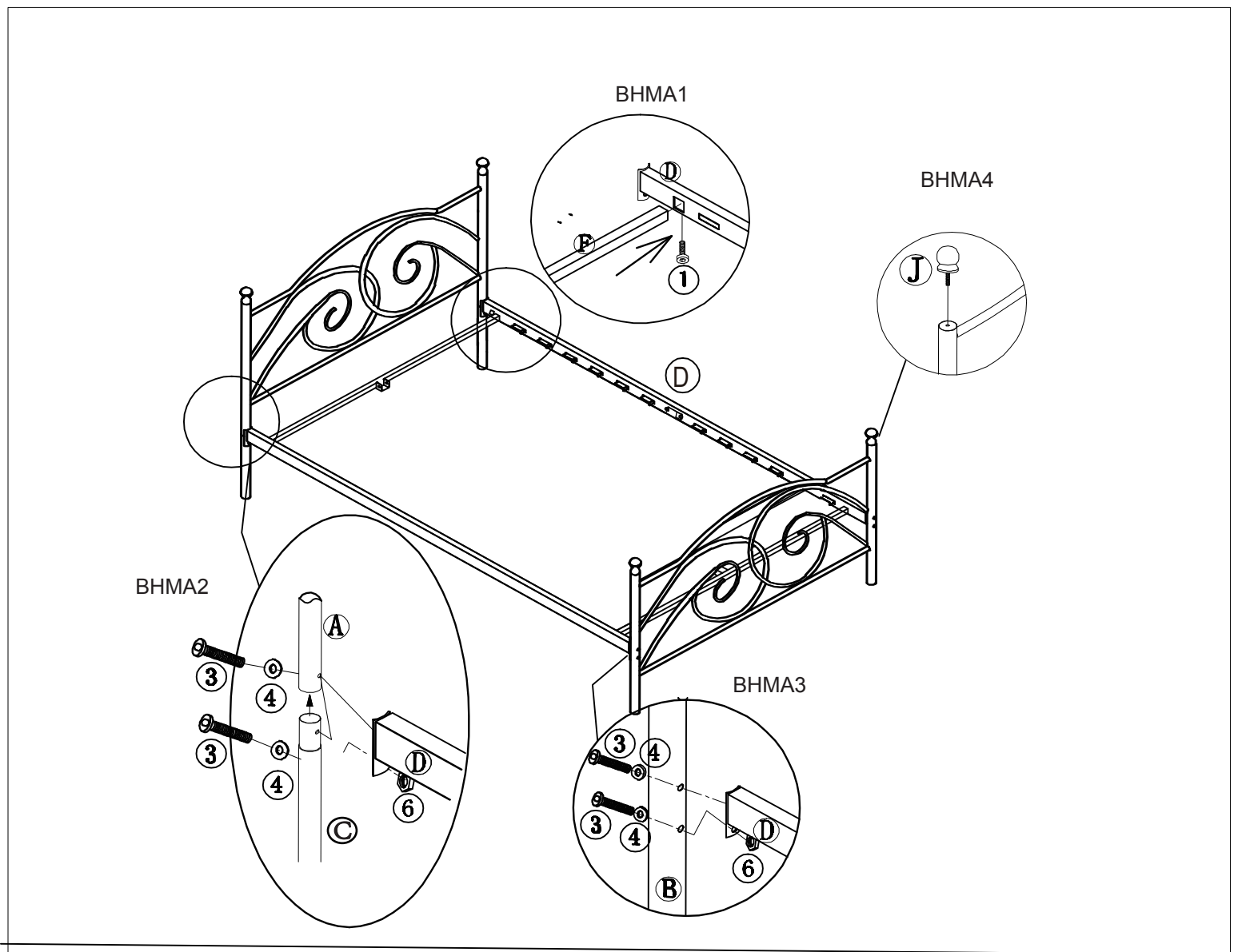
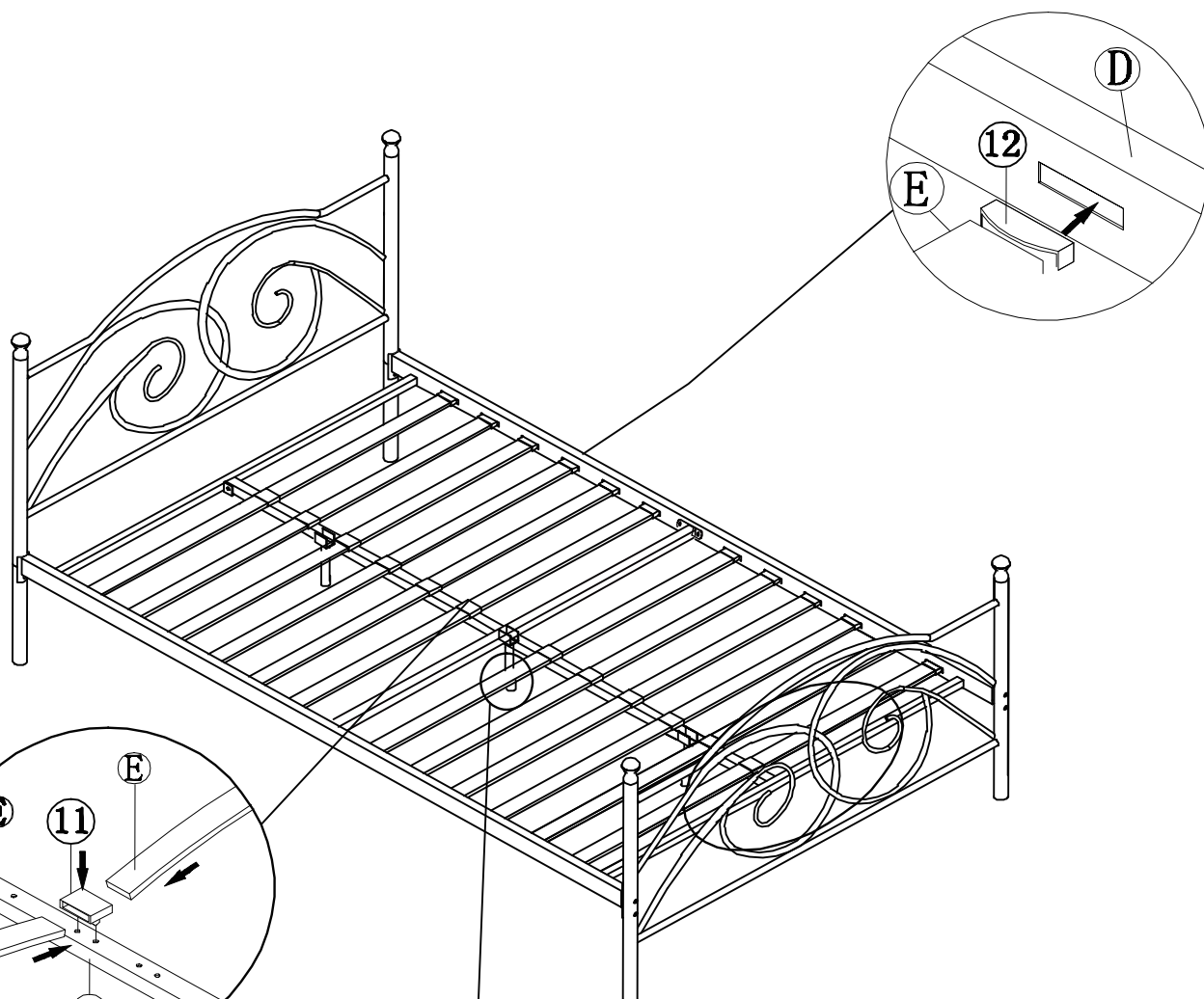

ΒΗΜΑ10

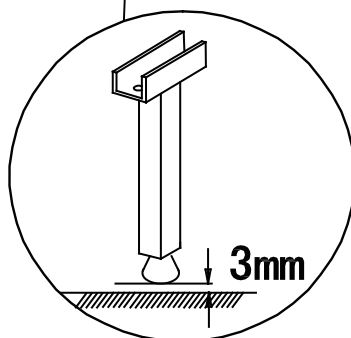
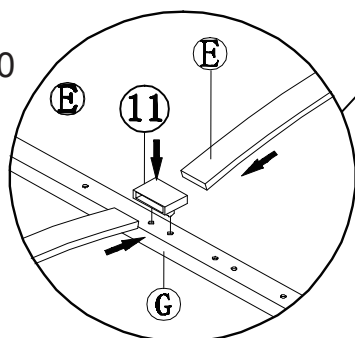

***ΠΡΟΣΟΧΗ:**

ΜΗΝ ΣΦΙΞΕΤΕ ΥΠΕΡΒΟΛΙΚΑ ΤΙΣ ΒΙΔΕΣ ΣΤΑ ΜΕΣΑΙΑ ΠΟΔΑΡΑΚΙΑ ΣΤΗΡΙΞΗΣ ,
ΣΤΟ ΤΕΛΟΣ ΤΗΣ ΣΥΝΑΡΜΟΛΟΓΗΣΗΣ ΘΑ ΠΡΕΠΕΙ ΝΑ ΥΠΑΡΧΕΙ ΚΕΝΟ ΑΝΑΜΕΣΑ ΣΤΟ ΠΟΔΑΡΑΚΙ
& ΤΟ ΠΑΤΩΜΑ 3mm.

ΤΑ ΠΟΔΑΡΑΚΙΑ ΘΑ ΑΚΟΥΜΠΗΣΟΥΝ ΣΤΟ ΠΑΤΩΜΑ ΜΟΝΟ ΟΤΑΝ ΥΠΑΡΞΕΙ ΒΑΡΟΣ ΠΑΝΩ ΣΤΟ
ΚΡΕΒΑΤΙ.

ΝΑ ΜΗΝ ΣΥΡΕΤΕ ΤΟ ΚΡΕΒΑΤΙ ΜΑΖΙ ΜΕ ΤΟ ΣΤΡΩΜΑ ΕΠΙΣΗΣ ΝΑ ΜΗΝ ΤΟ ΣΥΡΕΤΕ ΠΑΝΩ ΣΕ
ΧΑΛΙ Ή ΤΡΑΧΕΙΑ ΕΠΙΦΑΝΕΙΑ