

ASSEMBLY INSTRUCTION

Page 1

MODEL : (FLORA-E8028) DRESSING TABLE (MIRROR)

Before you begin, please follow Assembly Instruction carefully. Follow them step by step.

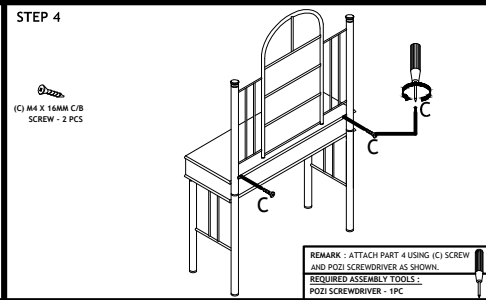
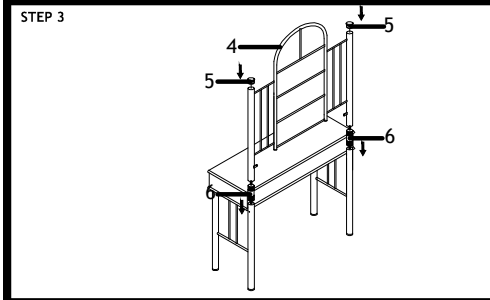
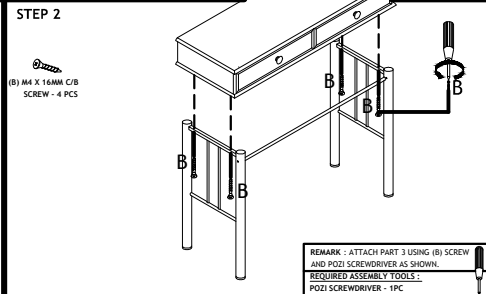
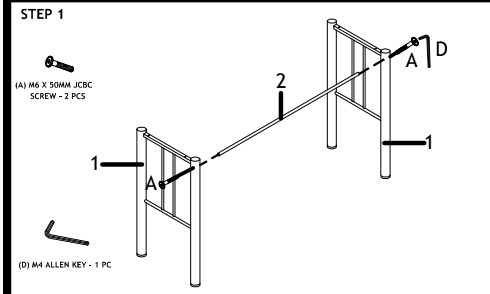

ASSEMBLY INSTRUCTION

Page 2

MODEL : (FLORA-E8028) DRESSING TABLE (MIRROR)

Before you begin, please follow Assembly Instruction carefully. Follow them step by step.

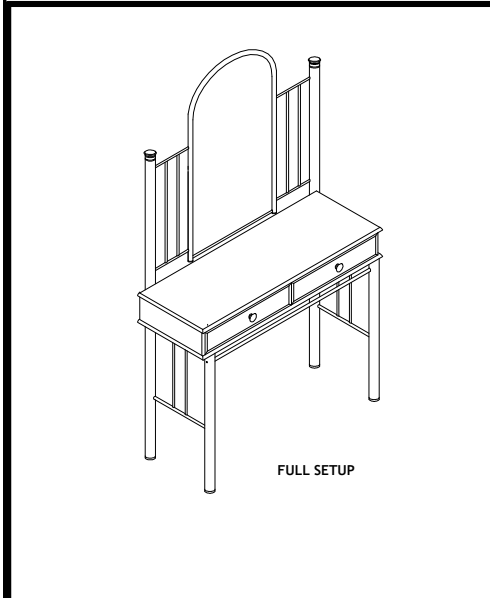

PART LIST	
1) TABLE LEGS X 2 SETS	4) MIRROR X 1 SET
2) PART A X 1 PC	5) CHROME CAP X 2 PCS
3) TABLE WITH DRAWER X 1 PC	6) METAL JOIN X 2 PCS
HARDWARE LIST	
(A) M6 X 50MM JCBC SCREW - 2 PCS	(C) M4 X 16 MM C/B SCREW - 2 PCS
(B) M4 X 32 MM C/B SCREW - 4 PCS	(D) M4 ALLEN KEY - 1 PC

ASSEMBLY INSTRUCTION

Page 1

MODEL : (FLORA-E8028) DRESSING TABLE (STOOL)

Before you begin, please follow Assembly Instruction carefully. Follow them step by step.

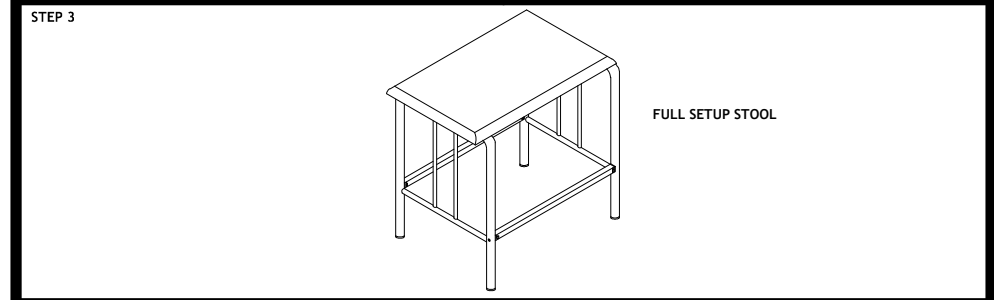
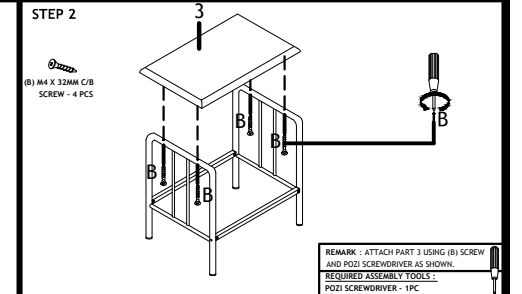
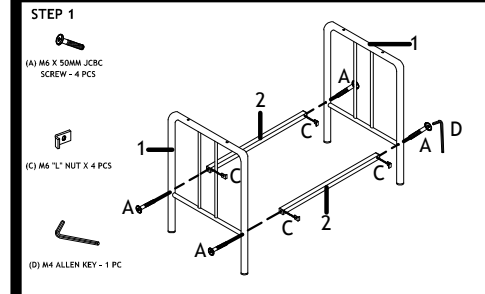

ASSEMBLY INSTRUCTION

Page 2

MODEL : (FLORA-E8028) DRESSING TABLE (STOOL)

Before you begin, please follow Assembly Instruction carefully. Follow them step by step.

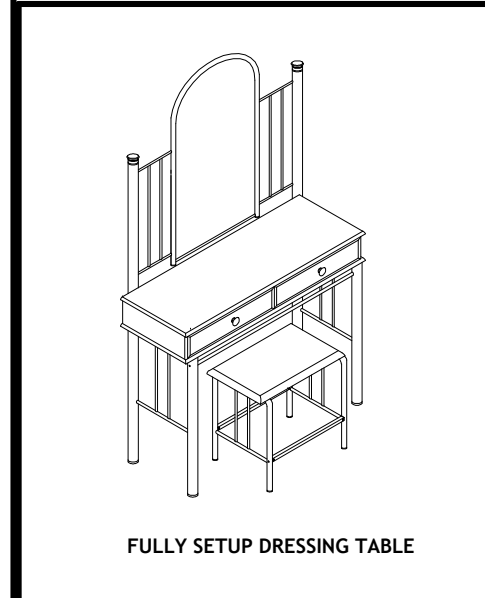

PART LIST	
1) TABLE LEGS X 2 SETS	
2) PART A X 1 PC	
3) CHAIR SEAT X 1 PC	
HARDWARE LIST	
(A) M6 X 50MM JCBC SCREW - 4 PCS	(C) M6 "L" NUTS X 4 PCS
(B) M4 X 32 MM C/B SCREW - 4 PCS	(D) M4 ALLEN KEY - 1 PC