

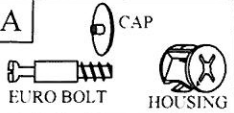



# ASSEMBLY INSTRUCTION

MODEL : PCT 1800

PART	QTY
A 	24 SETs

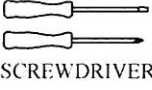
PART	QTY
C WOOD DOWEL M8 x 30mm 	4 pcs

Tools Required
 HAMMER
 SCREWDRIVER

PART	QTY
B 	5 pcs

PART	QTY
D 	4 pcs

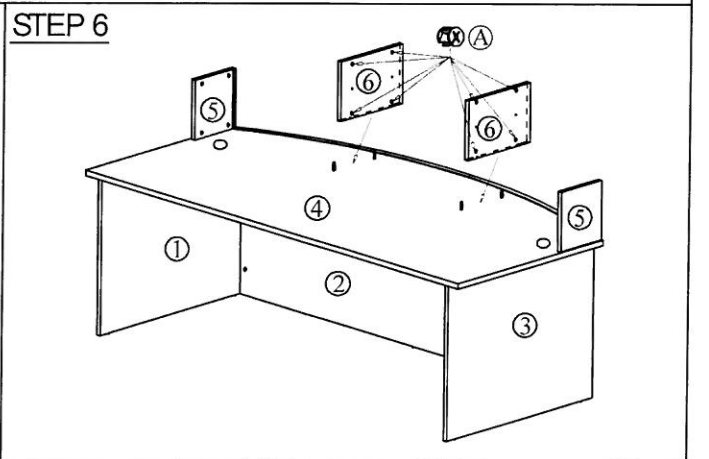
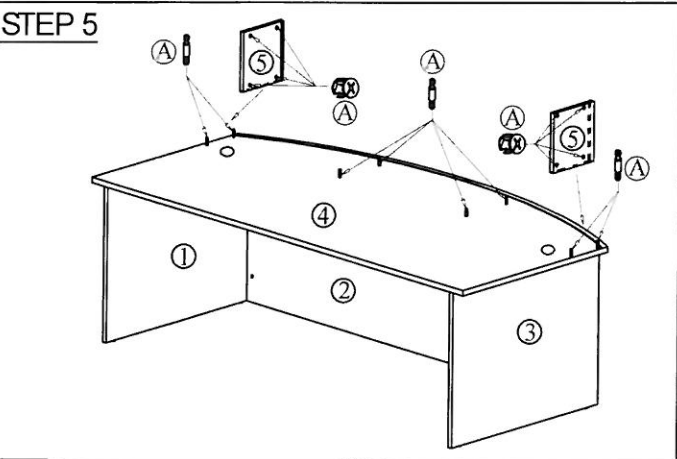
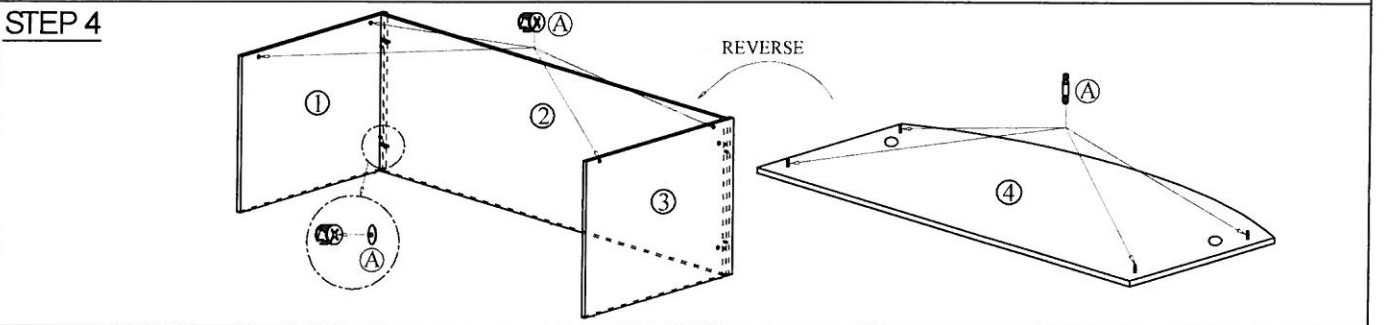
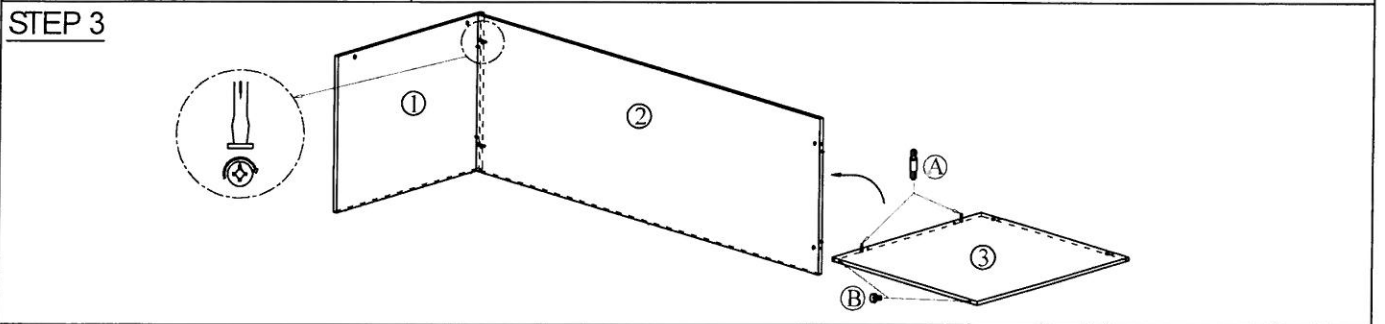
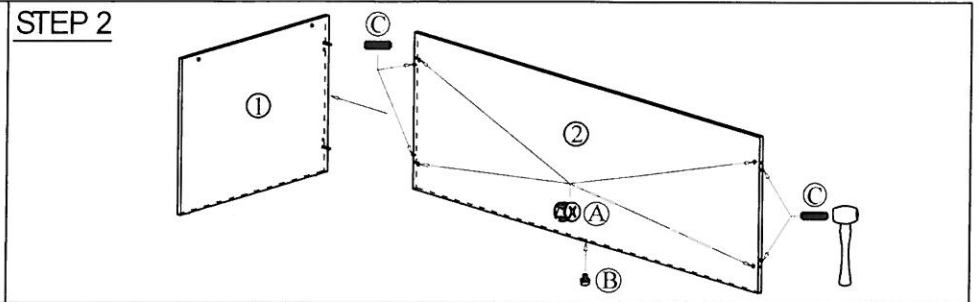
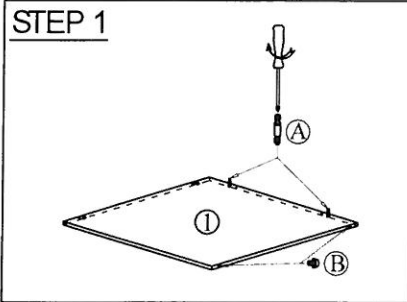

STEP 7

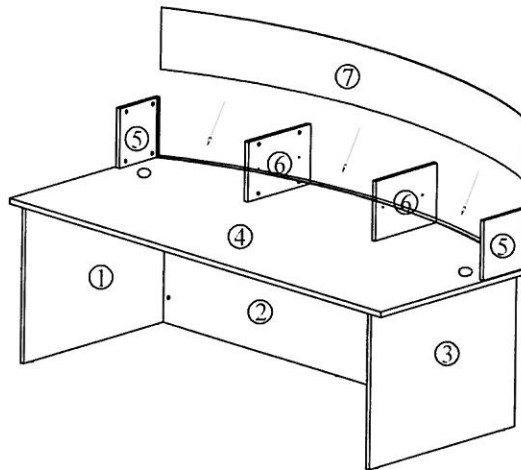

STEP 8

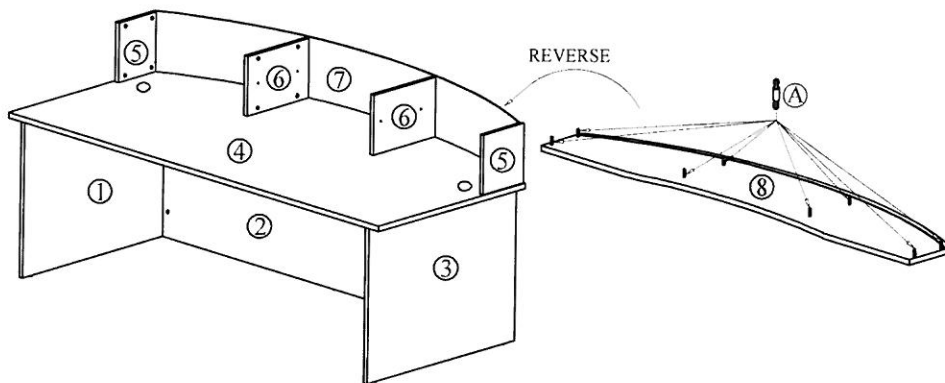

STEP 9

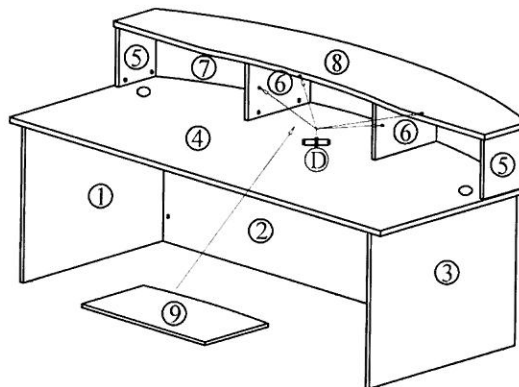

FINISHING

